

Tatiana Burgess

From: Kump, Casey V <Casey.Kump@osp.oregon.gov>
Sent: Thursday, April 7, 2022 11:23 AM
To: Tatiana Burgess
Cc: Eric Evans; jtolman@cityofvale.com; rachiebabyj@gmail.com; Kump, Casey V
Subject: Johnson Application - Rediron Beef Pack

Thank you for taking the time to discuss this Tatiana and Jason. This email is to offer comments related to access and water supply for the Johnson proposed meat packing plant located at T18 R45 S31, TL4201 (Reference # 20768). The authority for this review comes from the 2019 Oregon Fire Code, Chapter 5 sections 503, 507, Appendices B and D.

The location for the proposed facility is outside of a municipal or private water supply system. Appendix B (B107) directs the use of NFPA 1142 to calculate water storage for firefighting purposes in a rural setting. I spoke with Chief Tolman on this acceptable alternative to provide service to the property / facility. We calculated the storage tank size to be a minimum of 10,000 gallons. I will attempt to include pictures related to the standard to be used as a guide to support successful fire department drafting operations. In speaking with Jason Johnson we requested for the tank to be supported by an on-site well and potentially connected to the facility's domestic water use to provide circulation through the tank and ensure the water will be clean and the tank full in the event of an emergency. The tank needs to be located outside of the building collapse zone to provide safe access during a fire emergency. It is understood a domestic use connection may not be achieved and so at minimum we request the tank to be well-fed to ensure it will be full in the time of an emergency. The tank location will need to be positioned to provide fire apparatus access to the drafting (suction) piping.

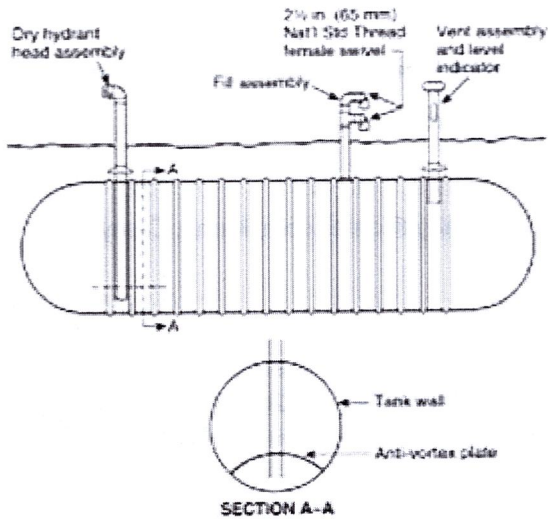
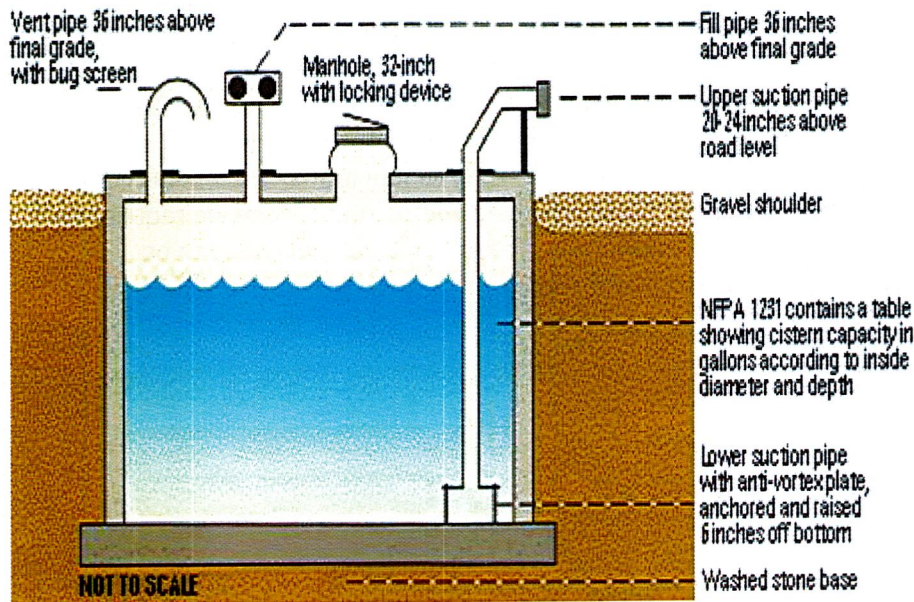

FIGURE B.5 Example of Construction of Water Cisterns Using an Underground Fiberglass Storage Tank.



We don't have any access related issues related to the site plan knowing it will already need to support large cattle-hauling vehicles.

Thank you, please contact myself or Chief Tolman with any questions as we work through this process.

Casey Kump
 Deputy State Fire Marshal
 Oregon Office of State Fire Marshal
 Oregon State Police
 3004 Blue Mountain Dr.
 La Grande, OR 97850
 W- 541-963-7175 Ext. 4000
 C - 541-786-9868
casey.kump@osp.oregon.gov
www.oregon.gov/osp/sfm
 Premier Public Safety Services